

256 and 240 C2 Series

Class 2 360° LED Lights
(10-30VDC Versions)

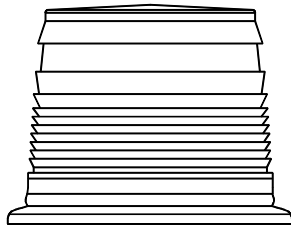

256TSL Series

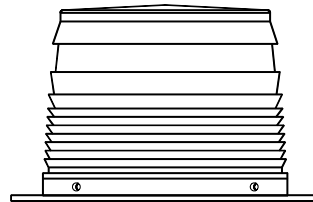

240SFL Series

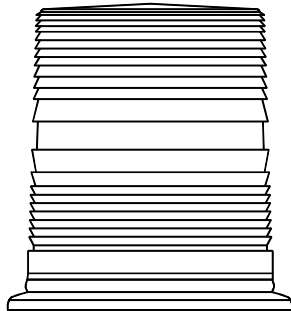

256TCL Series

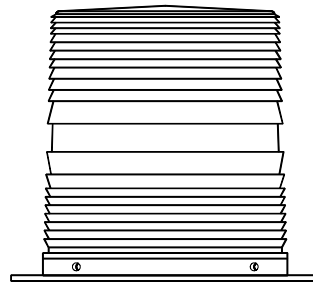

240CFL Series



PROUDLY MADE IN THE USA
An ISO 9001:2008 Certified Company



Star Headlight & Lantern Co., Inc.

455 Rochester Street Avon, NY 14414 Phone: 585-226-9787 FAX: 888-478-2797

STAR
WARNING
SYSTEMS

STAR SIGNAL
VEHICLE PRODUCTS

BRADFORD
Vehicle Solutions

www.starheadlight.com

PLIT501 REV. C 11/13/15

Magnet Mounting

WARNING!!! Care should be taken when positioning any warning light on the roof, dash, or instrument panel of the vehicle, so that the light and/or cord does not interfere with the proper operation of any airbags! Failure to heed this warning may result in serious or fatal injury.

If you are mounting the light on the roof of your vehicle, take extreme care to ensure that the magnet is firmly seated on your roof, and that the pull of the magnet is sufficient to secure the light in place. As the composition of the metal in the roofs of different vehicles may vary, as well as the contour, texture, and/or condition, Star cannot guarantee the ability of the light to remain in place upon a moving vehicle. It is the sole responsibility of the owner to ensure the warning light is secure.

- **CAUTION:** Please be sure to check that your cigarette plug outlet is properly fused. **Testing the light before this fuse is properly installed will void the warranty on the light.**
- Once the light is secured, route your cord such that it does not interfere with the vision of the driver or the operation of any controls, including, but not limited to, the steering wheel, gear shifter, and/or airbag.
- This light has been factory tested and approved. If the light fails to work when the plug is inserted into the cigarette plug socket, twist the plug a few times to remove any ash or other deposits which might be preventing a good contact from being made. If the problem persists, check for a fuse inside of the plug itself. If present, remove the fuse from the circuit, check to see if it has blown, and clean the lighter socket and contact surfaces. Reconnect the fuse and test the light again.

Permanent Mounting

1. **CAUTION:** All of our DC powered warning lights are polarity sensitive. These lights are polarity protected *only if the appropriate fuse is used*. All wires connected to the positive terminal of the battery should be fused at the battery for their rated load. **Testing the light before this fuse is properly installed will void the warranty on the light.**
2. Your new warning light comes complete with a foam mounting gasket, and mounting hardware.
3. Many of these warning lights come equipped with a combination base, allowing the light to be either mounted on threaded conduit pipe or permanently mounted. For NPT pipe, mount the light using the threaded entrance hole in the base of the light, then skip to the **Wiring Instructions**. For the permanent mount, proceed to Step 4.
4. Using the gasket as a template, mark and drill your mounting holes. Use a drill bit appropriate for the mounting hardware you will be using. Be sure to mark and drill the center hole if you will be running your wires through the mounting surface.
CAUTION: *If you are mounting the light on a vehicle, and plan to wire it through the roof of the vehicle, remove the headliner from the inside of the vehicle. If you do not remove the headliner, take care so that you do not drill through it.*
5. If using well nuts, push them through the mounting holes until the bottom side of the wider lip rests on the surface of the vehicle.
6. Install the wire grommet on the center hole (if applicable).
7. Place the light on the surface of the vehicle, routing the wires through the center hole, if necessary, install the screws through the base, into the well nuts or standard nuts, and tighten until snug.

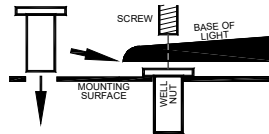

Wiring Instructions

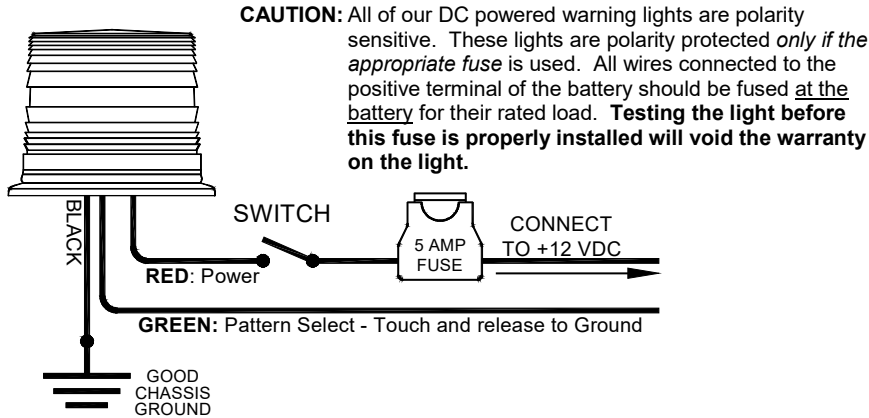

Pattern Programming

Depending upon your model, pressing the pattern select button on the cig plug, or touching the **green wire** to ground on hard-wired models, will allow you to change the flash pattern.



The unit has 26 patterns to choose from. After the final pattern is reached, the patterns will cycle through again. The UNIT will remember the pattern it was in when turned off and display the same pattern when re-activated.

Patterns

- | | |
|------------------------------------|--|
| 1. Slow Singleflash † | 14. Flicker |
| 2. Fast Singleflash † | 15. Delta Omega |
| 3. Superfast Singleflash | 16. Flicker-Flash |
| 4. Beacon Fade | 17. Super Combo/Mix Pattern |
| 5. Pre Pops | 18. Slow Doubleflash, Flicker |
| 6. Slow Doubleflash † | 19. Slow Doubleflash, Quadflash w/Post Pop |
| 7. Fast Doubleflash † | 20. Slow Double, Quint x2, Dual Quad w/Post Pop, Flicker |
| 8. Tripleflash † | 21. Quadflash w/Post Pop, Tripleflash, Flicker |
| 9. Pre-Pop Tripleflash † | 22. Delta Omega, Flicker, Slow Doubleflash |
| 10. Quadflash † (DEFAULT) | 23. Medium Singleflash † (T13) |
| 11. Fast Quadflash w/Post Pop † | 24. Medium Singleflash, Fast Singleflash (T13) |
| 12. Quintflash † | 25. Cycle all patterns |
| 13. Pre-Pop Quintflash † | 26. Steady On |

† - SAE Class 2 Approved Patterns when properly configured
 (T13) - California Title 13 Approved Patterns when properly configured

Flash Pattern Shortcuts

<u>Hold Pattern Select Button or Touch Green Wire to Ground</u>	<u>Light Flashes</u>	<u>Pattern Becomes</u>
3 seconds	1 Flash	Pattern 1 - Slow Singleflash
6 seconds	2 Flashes	Pattern 10 - Quadflash
9 seconds	3 Flashes	Pattern 21 - Quadflash w/Post Pop, Tripleflash, Flicker

Note: After programming the flash pattern, cut short and tape or cap off the Green wire so that it does not come into contact with ground or power.

LED FIVE YEAR LIMITED WARRANTY

The manufacturer warrants this LED light against factory defects in material and workmanship for five years after the date of purchase. The owner will be responsible for returning to the Service Center any defective item(s) with the transportation costs prepaid. The manufacturer will, without charge, repair or replace *at its option*, products, or part(s), which its inspection determines to be defective. Repaired or replacement item(s) will be returned to the purchaser with transportation costs prepaid from the service point. A copy of the purchaser's receipt must be returned with the defective item(s) in order to qualify for the warranty coverage. Exclusions from this warranty include, but are not limited to, dimes, and/or the finish. This warranty shall not apply to any light, which has been altered, such that in the manufacturer's judgment, the performance or reliability has been affected, or if any damage has resulted from abnormal use or service.

There are no warranties expressed or implied (including any warranty of merchantability or fitness), which extend this warranty period. **The loss of use of the product, loss of time, inconvenience, commercial loss or consequential damages, including costs of any labor, are not covered.** The manufacturer reserves the right to change the design of the product without assuming any obligation to modify any product previously manufactured.

This warranty gives you specific legal rights. You might also have additional rights that may vary from state to state. Some states do not allow limitations on how long an implied warranty lasts. Some states do not allow the exclusion or limitation of incidental or consequential damages. Therefore, the above limitation(s) or exclusion(s) may not apply to you.

If you have any questions concerning this or any other product, please contact our **Customer Service Department** at (585) 226-9787.

If a product must be returned for any reason, please contact our Customer Service Department to obtain a Returned Materials Authorization number (RMA #) before you ship the product back.
Please write the RMA # clearly on the package near the mailing label.



PROUDLY MADE IN THE USA
An ISO 9001:2008 Certified Company



Star Headlight & Lantern Co., Inc.

455 Rochester Street Avon, NY 14414 Phone: 585-226-9787 FAX: 888-478-2797

STAR
WARNING
SYSTEMS

STAR
SIGNAL
VEHICLE PRODUCTS

BRADFORD
Vehicle Solutions

www.starheadlight.com